



CP20

Quick Start Guide

EN FR ES IT ZH



Register your product online
to confirm your warranty
and benefit from the full
Sauermann range.

Quick Start Guide

These operating instructions describe the basic handling of the device.

Please refer to the operating instructions available at sauermanngroup.com for safe use of the product and detailed information.

Do not give this device to a child.

1. Symbols used

For your safety and in order to avoid any damage of the device, please read carefully the notes preceded by the following symbol: 

The following symbol will also be used in this document, please read carefully the information notes indicated after this symbol: 

2. Description of the device, operating temperature, protection of the instruments and information about storage

The CP20 is a transmitter that can measure differential pressure.

- Operating temperature: -40 to 60 °C (-40 to 140 °F)
- Protection: IP54
- Storage temperature: -40 to 70 °C (-40 to 158 °F)

3. Mounting

To install the transmitter on a wall drill two Ø6 mm holes and use the screws and wall-plugs to fix the transmitter.

 Once the transmitter is installed and powered up, please make an autozero to guarantee the correct working of the transmitter in any position.

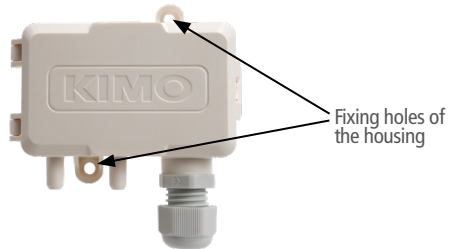

4. Connections

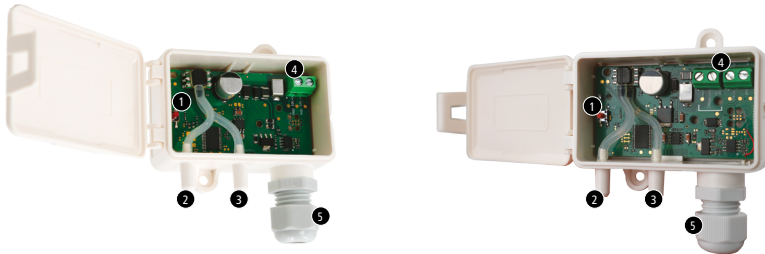

1. Autozero button
2. P+ connector
3. P- connector

4. Power supply terminal block
5. Cable gland

5. Electrical connections as per NFC15-100 standard



This connection must be made by a formed and qualified technician. Whilst making the connection, the transmitter must not be energized. The presence of a switch or a circuit breaker upstream the device is compulsory.

Active models

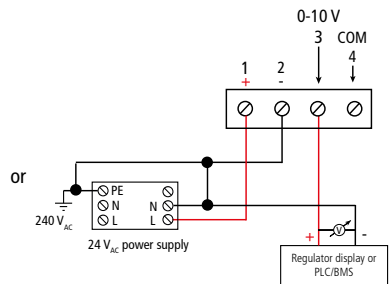
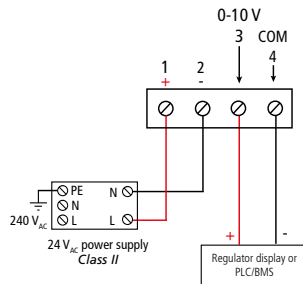
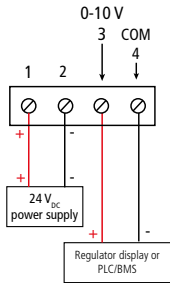
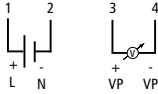

Passive models

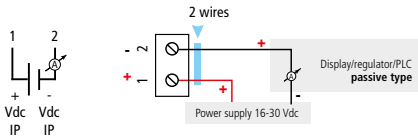

6. Maintenance

Please avoid any aggressive solvents. Please protect the transmitter and its probes from any cleaning product containing formalin, that may be used for cleaning rooms or ducts.

7. Precautions for use

Please always use the device in accordance with its intended use and within parameters described in the user manual in order not to compromise the protection ensured by the device.

Guide rapide

Ce document décrit les manipulations de base de l'appareil.

Veuillez consulter la notice d'utilisation disponible sur le site sauermanngroup.com pour une utilisation sûre du produit et pour les informations détaillées.

Ne pas donner cet appareil à un enfant.

1. Symboles utilisés

Pour votre sécurité et afin d'éviter tout endommagement de l'appareil, veuillez lire attentivement les notes précédées du symbole suivant :



Le symbole suivant sera également utilisé dans ce document. Veuillez lire attentivement les notes d'information indiquées après ce symbole.



2. Description de l'appareil, température d'utilisation, protection de l'appareil et information sur le stockage

Le CP20 est un transmetteur qui mesure la pression différentielle.

- Température d'utilisation : -40 à 60 °C (-40 à 140 °F)
- Protection : IP54
- Température de stockage : -40 à 70 °C (-40 à 158 °F)

3. Montage

Pour installer et fixer le transmetteur sur un mur, percez deux trous de Ø6 mm et utilisez les vis et les chevilles fournies.

 Une fois le capteur mis en place et sous tension, effectuer la procédure d'autozéro garantissant le bon fonctionnement du capteur, quelle que soit sa position de montage.

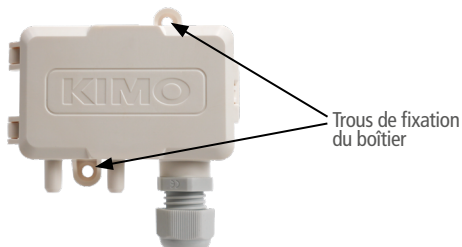

4. Connexions

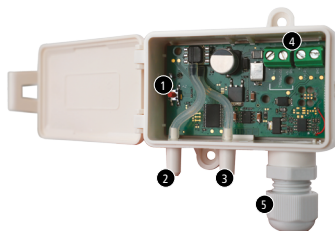
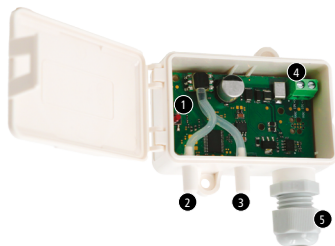

1. Bouton Autozéro
2. Prise de pression P+
3. Prise de pression P-

4. Bornier d'alimentation électrique
5. Presse-étoupe

5. Raccordements électriques suivant normes NF C 15-100



Seul un technicien formé et qualifié peut réaliser cette opération. Pour réaliser le raccordement, l'appareil doit être HORS TENSION. La présence d'un interrupteur ou d'un disjoncteur en amont de l'appareil est obligatoire.

Modèle actif

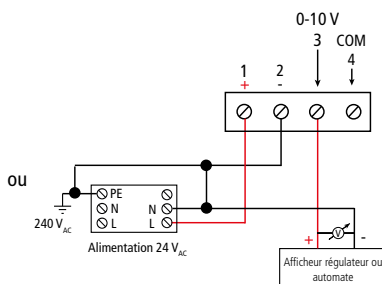
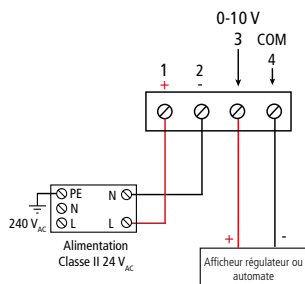
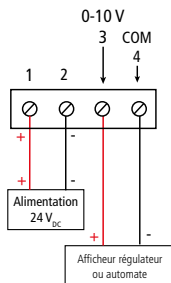
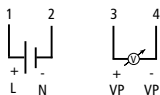

Modèle passif

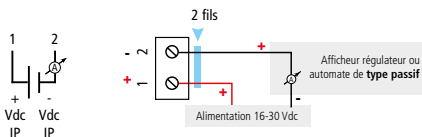

6. Maintenance

Éviter tous les solvants agressifs. Lors du nettoyage à base de produits formolés (pièces ou conduits), protéger l'appareil et ses sondes.

7. Précautions d'utilisation

Veillez à toujours utiliser l'appareil conformément à l'usage prévu et dans les limites des paramètres décrits dans les caractéristiques techniques afin de ne pas compromettre la protection assurée par l'appareil.

Guía rápida

Este documento describe las manipulaciones básicas del dispositivo.

Para una utilización segura del producto o si necesita más detalles, consulte el manual de utilización disponible en la web sauermanngroup.com.

No deje el dispositivo al alcance de los niños.

1. Símbolos utilizados

Por su seguridad y para evitar posibles daños en el dispositivo, lea atentamente las notas precedidas por el símbolo siguiente:



En este documento también se utiliza el siguiente símbolo. Lea atentamente las notas informativas que le siguen.



2. Descripción del dispositivo, temperatura de utilización, protección del dispositivo y temperatura de almacenamiento

El CP20 es un transmisor que mide la presión diferencial.

- Temperatura de utilización: -40 a 60 °C (-40 a 140 °F)
- Protección: IP54
- Temperatura de almacenamiento: -40 a 70 °C (-40 a 158 °F)

3. Montaje

Para instalar y fijar el transmisor a la pared, taladre dos agujeros de Ø6 mm y utilice los tornillos y tacos suministrados.

 Una vez el equipo esté instalado y alimentado, se recomienda efectuar el pceso de ajuste del cero para garantizar un funcionamiento óptimo, sea cual sea su posición de montaje.

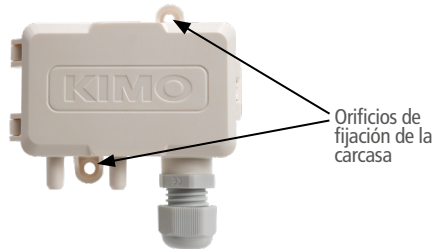

4. Conexiones

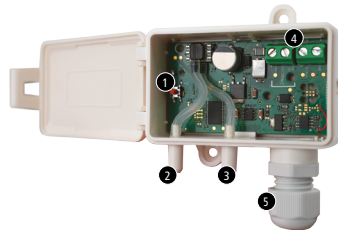
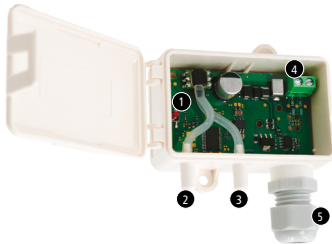

1. Botón Autozero
2. Toma de presión P+
3. Toma de presión P-

4. Bloque de terminales de alimentación
5. Prensaestopas

5. Conexiones eléctricas según las normas NF C 15-100



Esta operación debe ser realizada exclusivamente por un técnico formado y cualificado. Para realizar la conexión, el dispositivo debe estar **DESCONECTADO DE LA CORRIENTE**. Es obligatorio instalar un interruptor o disyuntor antes del dispositivo.

Modelo activo

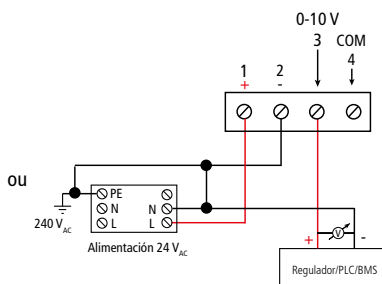
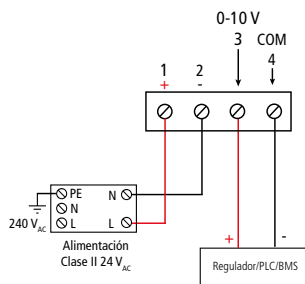
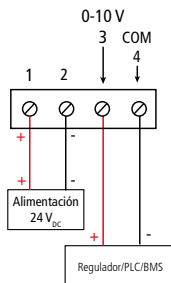
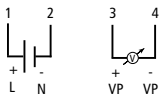

Modelo pasivo

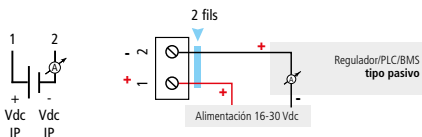

6. Mantenimiento

Evite los disolventes agresivos. Durante la limpieza con productos que contengan formol (piezas o conductos), proteja el dispositivo y sus sondas.

7. Precauciones de utilización

Utilice siempre el dispositivo de conformidad con su uso previsto y dentro de los límites de los parámetros descritos en las especificaciones técnicas para no comprometer la protección que ofrece el dispositivo.

Guide rapide

Questa guida descrive l'utilizzo base del dispositivo.

Fare riferimento alle istruzioni per l'uso disponibili su sauermanngroup.com per un uso sicuro del prodotto e informazioni dettagliate.

Tenere lontano dalla portata dei bambini.

1. Simboli utilizzati

Per la vostra sicurezza e per evitare danni al dispositivo, vi preghiamo di leggere attentamente le note precedute dal seguente simbolo:



Anche il seguente simbolo è utilizzato in questo documento, si prega di leggere attentamente le note informative:



2. Descrizione del dispositivo, temperatura di funzionamento, protezione e informazioni sulla conservazione

Il CP20 è un trasmettitore che misura la pressione differenziale.

- Temperatura di funzionamento: -40 a 60 °C (-40 a 140 °F)
- Protezione: IP54
- Temperatura di conservazione: -40 a 70 °C (-40 a 158 °F)

3. Montaggio

Per installare e fissare il trasmettitore a una parete, praticare due fori di Ø6 mm e utilizzare le viti e i tasselli in dotazione.

 Una volta che il trasmettitore è installato e acceso, eseguire un autozero per garantire il corretto funzionamento del trasmettitore in qualsiasi posizione.

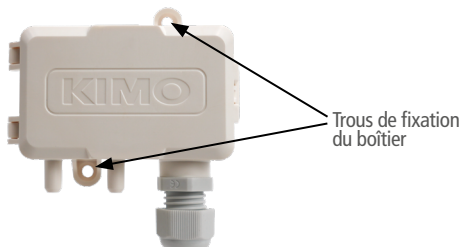

4. Connessioni

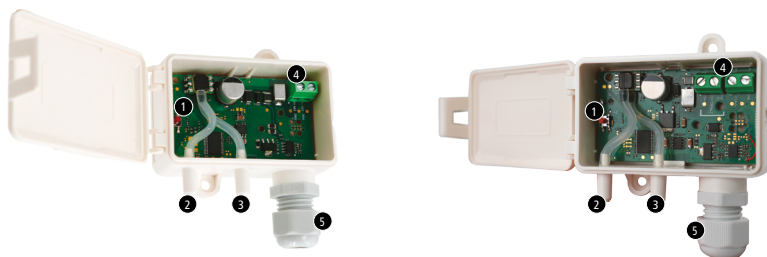

1. Pulsante Autozero
2. Presa di pressione P+
3. Presa di pressione P-

4. Blocco terminale alimentazione
5. Passacavo

5. Collegamenti elettrici secondo lo standard NFC15-100



Questo collegamento deve essere effettuato da un tecnico formato e qualificato. Durante la connessione il trasmettitore deve essere spento. E' obbligatoria la presenza di un interruttore o di un salvavita a monte del dispositivo.

Modello attivo

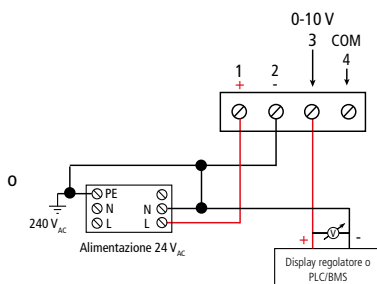
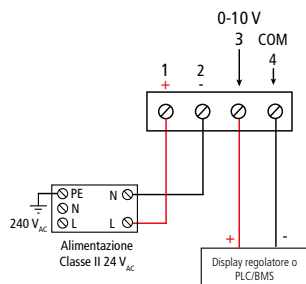
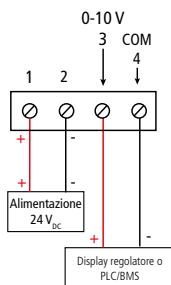
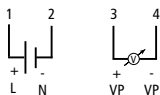

Modello passivo

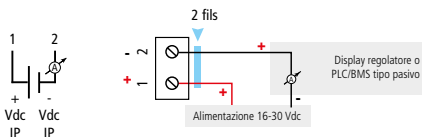

6. Manutenzione

Si prega di evitare solventi aggressivi. Si prega di proteggere il trasmettitore e le sue sonde da qualsiasi prodotto detergente contenente formalina, che potrebbe essere utilizzato per la pulizia di stanze o canali.

7. Precauzioni per l'uso

Si prega di utilizzare sempre il dispositivo secondo la sua destinazione d'uso e rimanendo all'interno del campo dei parametri di funzionamento descritti nel manuale d'uso per non comprometterne l'integrità.

中文 快速入门指南

本指南仅描述了此变送器的基本操作方法。

更详细的操作手册以及产品使用安全等信息请参阅官网的内容 (sauermanngroup.com)。请勿让儿童接触设备。

1. 符号使用说明

为了您的人身安全和避免设备发生损坏, 请严格参照本手册的使用方法操作仪器, 并仔细阅读标注此符号注释内容:

此操作手册中也使用下述符号, 请仔细阅读此符号后面标注的信息说明。



2. 产品描述, 操作温度, 防护等级和存储要求

CP20 差压变送器可以用来测量差压。

- 操作温度: $-40 \sim +60 \text{ }^{\circ}\text{C}$ ($-40 \sim 140 \text{ }^{\circ}\text{F}$)
- 防护等级: IP54
- 存储温度: $-40 \sim +70 \text{ }^{\circ}\text{C}$ ($-40 \sim 158 \text{ }^{\circ}\text{F}$)

3. 安装方式

在墙壁上钻两个直径 $\text{Ø} 6 \text{ mm}$ 的孔洞, 然后用随货提供的螺丝和膨胀螺栓固定。



变送器安装完成并接电后, 请进行校准调零, 以确保变送器在任何位置都能正常工作。



安装固定孔位

4. 接线图

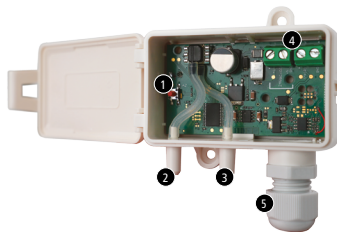
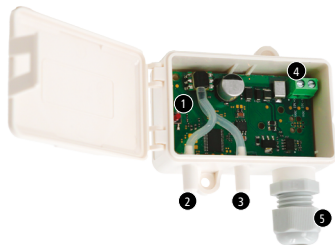

1. 零点校准 按键
2. 正压 (P+) 接头
3. 负压 (P-) 接头

4. 电源供应
5. 电缆接头

5. 符合 NFC15-100 标准



接线应由合格技术人员操作。当接线时，变频器必须停止供应电源。必须在设备上游安装开关或断路器。

主动模式

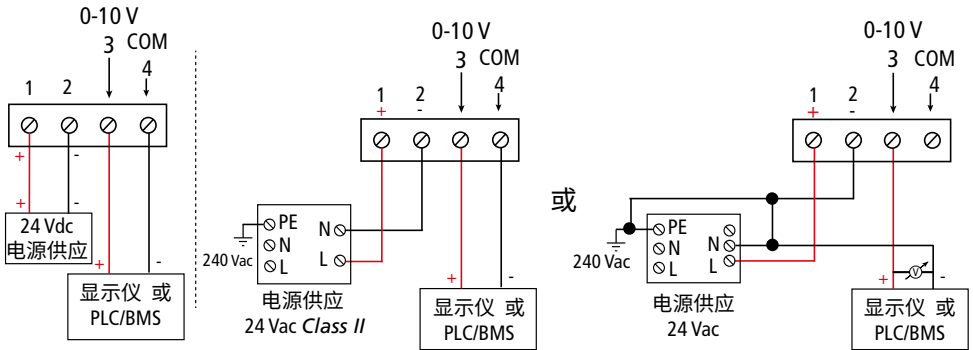
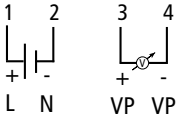

被动模式

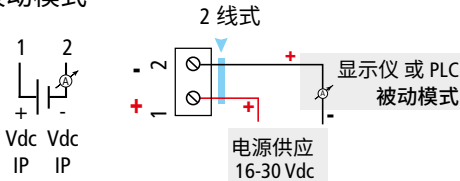

6. 维修保养

请避免使用刺激性溶剂或使用含有甲醛(福尔马林)成分的清洁剂清洁变送器和探头。

7. 使用注意事项

为了不损害设备的保护功能, 请始终遵照仪器的用途在测量参数范围内使用。



Register your product online to confirm your warranty and benefit from the full Sauermann range.

Enregistrez votre produit en ligne pour confirmer votre garantie et bénéficier de l'ensemble de la gamme Sauermann.

Registre su producto online para confirmar su garantía y beneficiarse de toda la gama Sauermann.

Registra il tuo prodotto online per confermare la garanzia e beneficiare del supporto sull'intera gamma Sauermann.

Registrieren Sie Ihr Produkt online, um Ihre Garantie zu bestätigen und das gesamte Sauermann-Sortiment zu nutzen.

在线注册您的产品，确认保修并享受索尔曼的全套服务。



Access all documentation about the device.
Accédez à toute la documentation sur l'appareil.
Accede a toda la documentación sobre el instrumento.
Accedi a tutta la documentazione del dispositivo.
Zugriff auf die gesamte technische Dokumentation des Geräts.
Acesse toda a documentação sobre o instrumento.
Krijg alle documentatie over jouw apparaat.
访问设备的所有文档。

Customer service portal / Portail service clients Portal de servicio al cliente / Portale servizio clienti / Kundendienst-Portal

Use our Customer service portal to contact us
Utilisez notre Portail service clients pour nous contacter
Contacte con nosotros a través del Portal de servicio al cliente
Utilizzate il nostro Portale servizio clienti per contattarci
Nutzen Sie unser Kundendienstportal, um mit uns Kontakt aufzunehmen

<https://sauermann-en.custhelp.com>

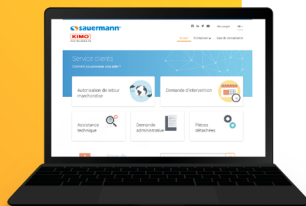

Kimo, a Sauermann brand.

sauermanngroup.com

Sauermann Industrie

ZA Bernard Moulinet

24700 Montpon-Ménéstérol - France

+33 (0)5 53 80 85 00

services@sauermanngroup.com



FR

Cet appareil,
ses accessoires
et piles
se recyclent

À DÉPOSER
EN MAGASIN



À DÉPOSER
EN DÉCHÈTERIE



OU

Points de collecte sur www.quefairedemesdechets.fr
Privilégiez la réparation ou le don de votre appareil !

